

TECHNICAL DATASHEET FERBORAIN

GB



Illustrative purposes only; the model shown here could be different that one supplied

STANDARD EQUIPMENT

- High efficiency partial flow turbine drive directly coupled to the gearbox (minimum pressure losses in its category)
- 4 speed gearbox with oil lubrication
- Safety devices for PTO and rewinding out of the drum
- Moving transmission through toothed crown, which is placed close to the maximum stress point on the drum and not pushing against the hose reel borders
- Leadscrew driven hose layering guide
- By-pass “double action” for automatic speed control
- Glycerine filled pressure gauge
- Digital hour meters
- Huge diameter 360° turntable
- Rotation system for the upper turret
- Mechanical trolley lift and staker legs operations
- Additional staker legs on the tow-bar
- Hot galvanised steel lower frame, upper frame, pipework with double water inlet and components
- 3 wheels hot galvanised sprinkler trolley with adjustable track
- Accident prevention protections according to CE standard
- Sprinkler with set of nozzles
- High resistant medium density PE hose with constant thickness
- Instructions and maintenance handbook
- CE Certificate
- Warranty certificate

Available Models

Structure	Model	Type	Ending hose	P.E. Hose Ø (mm)	Hose length (m)	Sprinkler
GB	70 / 300	A	8	70	300	ROYAL / TWIN 101
	70 / 400	C	5	70	400	ROYAL / TWIN 101
	75 / 300	A	9	75	300	ROYAL / TWIN 101
	75 / 350	C	2	75	350	ROYAL / TWIN 101
	82 / 220	B	3	82	220	ROYAL / TWIN 101
	82 / 250	B	5	82	250	ROYAL / TWIN 101
	82 / 300	D	9	82	300	ROYAL / TWIN 101
	90 / 220	E	3	90	220	REFLEX / TWIN 140
	90 / 240	E	5	90	240	REFLEX / TWIN 140

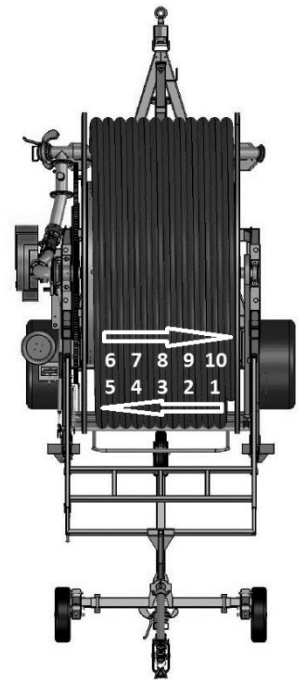

Weight and overall dimensions

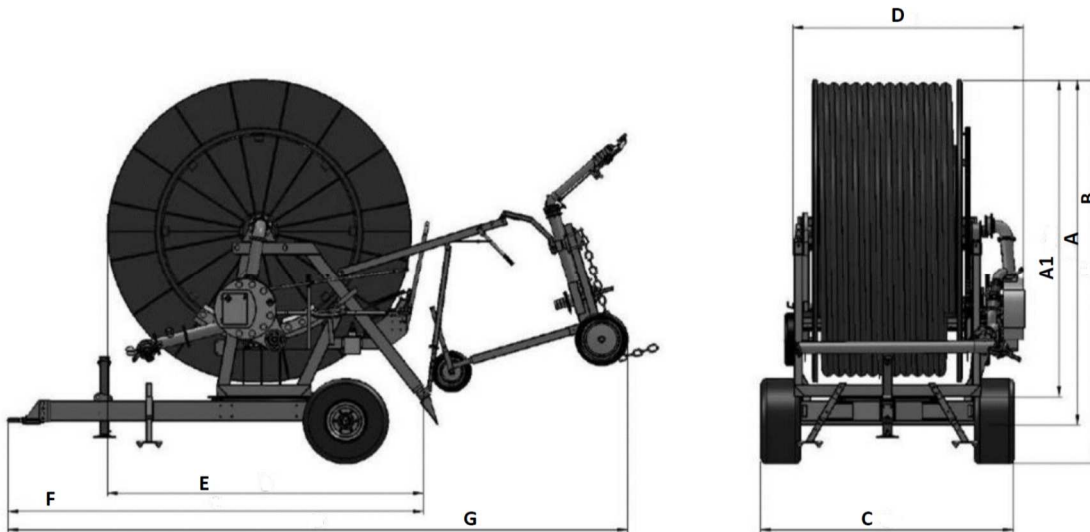

STR.	TYPE	WHEELS	A1	A	B	C	D	E	F	G	KG
GB	A	205/60.15-5F	2020	2200	2500	1800	1740	2090	3190	4800	1500 ÷ 1600
	B	205/60.15-5F	2020	2200	2500	1800	1740	2090	3190	4800	
	C	205/60.15-5F	2120	2300	2600	1800	1740	2190	3190	4800	
	D	205/60.15-5F	2120	2300	2600	1800	1740	2190	3190	4800	
	E	205/60.15-5F	2120	2300	2600	1800	1740	2190	3190	4800	

Technical Features

Ø hose (mm)	Ø nozzle (mm)	Machine pressure (atm)			Sprinkler press. (atm)	Throw (mt)	Irrigated width (mt)	Flow (l/min)	Irrigated area (ha)			Rainfall (mm)		
		300	400						300	400				
70	16	3,5	3,8		2,0	27,0	45,9	225	1,39	1,83		27,7	9,2	5,5
		4,9	5,4		3,0	32,0	54,4	275	1,67	2,18		28,2	9,4	5,6
	18	5,7	6,5		3,0	33,0	56,1	350	1,72	2,26		34,7	11,6	6,9
		7,4	8,4		4,0	37,0	62,9	403	1,95	2,55		35,4	11,8	7,1
	20	8,8	10,2		4,0	39,0	66,3	500	2,06	2,69		41,5	13,8	8,3
		11,3	13,4		4,5	41,5	70,6	620	2,21	2,88		48,1	16,0	9,6
75	16	300	350						300	350				
		4,2	4,4		3,0	27,0	45,9	225	1,39	1,61		27,7	9,2	5,5
	5,5	5,8		4,0	32,0	54,4	275	1,67	1,92		28,2	9,4	5,6	
	18	6,1	6,5		4,0	33,0	56,1	350	1,72	1,99		34,7	11,6	6,9
		7,6	8,0		5,0	37,0	62,9	403	1,95	2,25		35,4	11,8	7,1
	20	8,6	9,2		5,0	39,0	66,3	500	2,06	2,38		41,5	13,8	8,3
10,5		11,5		5,5	41,5	70,6	620	2,21	2,54		48,1	16,0	9,6	
82	18	220	250	300					220	250	300			
		4,2	4,3	4,5	3,0	33,0	56,1	350	1,30	1,46	1,72	33,9	11,3	6,8
	5,4	5,5	5,8	4,0	37,0	62,9	403	1,47	1,65	1,95	34,4	11,5	6,9	
	20	5,8	6,0	6,5	4,0	39,0	66,3	500	1,56	1,75	2,06	40,2	13,4	8,0
		7,2	7,4	7,9	5,0	43,0	73,1	560	1,74	1,95	2,29	40,4	13,5	8,1
	22	7,8	8,1	8,9	5,0	45,0	76,5	675	1,83	2,05	2,41	46,3	15,4	9,3
8,5		8,9	9,7	5,5	46,5	79,1	708	1,90	2,12	2,50	46,8	15,6	9,4	
90	24	220	240						220	240				
		4,8	5,0		3,0	39,0	66,3	622	1,56	1,68		50,0	16,7	10,0
	6,2	6,4		4,0	44,0	74,8	720	1,78	1,93		50,6	16,9	10,1	
	26	6,8	7,0		4,0	47,0	79,9	845	1,92	2,07		55,2	18,4	11,0
		8,4	8,6		5,0	52,0	88,4	945	2,15	2,32		55,0	18,3	11,0
	28	9,2	9,6		5,0	56,0	95,2	1095	2,35	2,53		58,5	19,5	11,7
10,1		10,4		5,5	57,0	96,9	1150	2,39	2,58		60,2	20,1	12,0	