

TECHNICAL DATASHEET FERBORAIN

GC



Illustrative purposes only; the model shown here could be different that one supplied

STANDARD EQUIPMENT

- High efficiency partial flow turbine drive directly coupled to the gearbox (minimum pressure losses in its category)
- 4 speed gearbox with oil lubrication
- Safety devices for PTO and rewinding out of the drum
- Moving transmission through toothed crown, which is placed close to the maximum stress point on the drum and not pushing against the hose reel borders
- Leadscrew driven hose layering guide
- By-pass “double action” for automatic speed control
- Glycerine filled pressure gauge
- Digital hour meters
- Huge diameter 360° turntable
- Exclusive “safety lock” rotation system from trolley lift which blocks the automatic rotation in case of emergency and allows a single operator to turn the machine safely and with minimum effort
- Trolley lift and stacker legs driven by hydraulic pistons incorporated inside the structure
- Additional stacker legs on the tow-bar
- Hot galvanised steel lower frame, upper frame, pipework with double water inlet and components
- 3 wheels hot galvanised sprinkler trolley with adjustable track, height and legs
- Accident prevention protections according to CE standard
- Sprinkler with set of nozzles
- High resistant medium density PE hose with differentiated thickness from $\varnothing 90$ mm
- Instructions and maintenance handbook
- CE Certificate
- Warranty certificate

Available Models

Structure	Model	Type	Ending hose	P.E. Hose Ø (mm)	Hose length (m)	Sprinkler
GC	75 / 400	C	8	75	400	ROYAL / TWIN 101
	75 / 450	B	2	75	450	ROYAL / TWIN 101
	82 / 320	C	5	82	320	ROYAL / TWIN 101
	82 / 360	A	8	82	360	ROYAL / TWIN 101
	82 / 400	A	10	82	400	ROYAL / TWIN 101
	82 / 440	E	3	82	440	ROYAL / TWIN 101
	90 / 260	C	2	90	260	REFLEX / TWIN 140
	90 / 300	C	5	90	300	REFLEX / TWIN 140
	90 / 350	B	9	90	350	REFLEX / TWIN 140
	90 / 380	F	10	90	380	REFLEX / TWIN 140
	100 / 210	C	10	100	210	REFLEX / TWIN 140
	100 / 250	D	3	100	250	REFLEX / TWIN 140
	100 / 270	D	4	100	270	REFLEX / TWIN 140
	100 / 300	H	5	100	300	REFLEX / TWIN 140
	110 / 200	C	10	110	200	REFLEX / TWIN 160
	110 / 250	F	4	110	250	REFLEX / TWIN 160

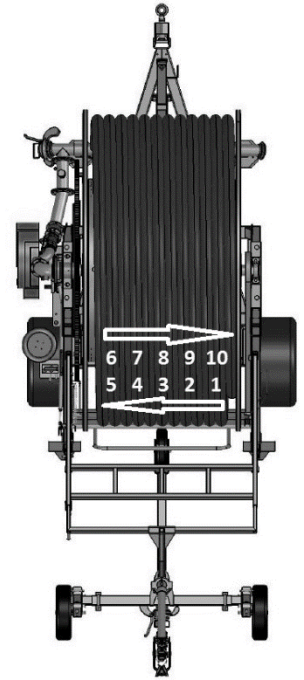

Weight and overall dimensions

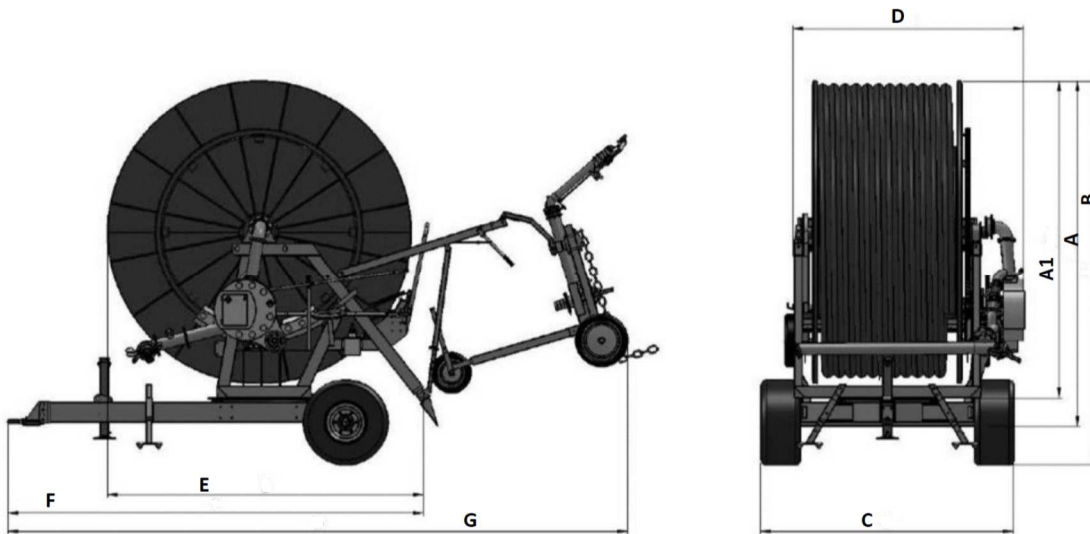

STR.	TYPE	WHEELS	A1	A	B	C	D	E	F	G	KG
GC	A	10.0/80.12-5F	2170	2420	2740	2050	1940	2340	3500	5100	2000 ÷ 2100
	A	10.0/75.15.3-5F	2170	2420	2770	2080	1940	2340	3500	5100	
	B	10.0/80.12-5F	2200	2450	2770	2050	1940	2370	3500	5100	
	B	10.0/75.15.3-5F	2200	2450	3000	2080	1940	2370	3500	5100	
	C	10.0/80.12-5F	2170	2420	2740	2050	1940	2340	3500	5100	
	C	10.0/75.15.3-5F	2170	2420	2770	2080	1940	2340	3500	5100	
	D	10.0/80.12-5F	2200	2450	2770	2050	1940	2370	3500	5100	
	D	10.0/75.15.3-5F	2200	2450	2800	2080	1940	2370	3500	5100	
	E	10.0/80.12-5F	2260	2510	2830	2050	1940	2430	3500	5100	
	E	10.0/75.15.3-5F	2260	2510	2860	2080	1940	2430	3500	5100	
	F	10.0/80.12-5F	2260	2510	2830	2050	1940	2430	3500	5100	
	F	10.0/75.15.3-5F	2260	2510	2860	2080	1940	2430	3500	5100	
H	10.0/80.12-5F	2260	2510	2830	2050	1940	2430	3500	5100		
H	10.0/75.15.3-5F	2260	2510	2860	2080	1940	2430	3500	5100		

Technical Features

Ø hose (mm)	Ø nozzle (mm)	Machine pressure (atm)				Sprinkler press. (atm)	Throw (mt)	Irrigated width (mt)	Flow (l/min)	Irrigated area (ha)				Rainfall (mm)		
		400	450	500						400	450	500				
75	16	4,6	4,7	4,8		3,0	27,0	45,9	225	1,83	2,04	2,26		28,1	9,4	5,6
		6,0	6,2	6,4		4,0	32,0	54,4	275	2,18	2,44	2,70		28,7	9,6	5,7
	18	6,9	7,2	7,5		4,0	33,0	56,1	350	2,26	2,52	2,79		35,4	11,8	7,1
		8,6	9,0	9,4		5,0	37,0	62,9	403	2,55	2,84	3,14		36,1	12,0	7,2
	20	10,1	10,6	11,2		5,0	39,0	66,3	500	2,69	3,01	3,32		42,3	14,1	8,5
		12,7	13,6	14,4		5,5	41,5	70,6	620	2,88	3,21	3,55		49,1	16,4	9,8
82	18	320	360	400	440					320	360	400	440			
		4,7	5,0	5,2	5,4	3,0	33,0	56,1	350	1,83	2,04	2,26	2,47	34,9	11,6	7,0
	20	6,1	6,5	6,7	6,9	4,0	37,0	62,9	403	2,07	2,31	2,55	2,78	35,6	11,9	7,1
		6,9	7,4	7,8	8,1	4,0	39,0	66,3	500	2,19	2,44	2,69	2,94	41,7	13,9	8,3
	22	8,4	9,1	9,5	9,9	5,0	43,0	73,1	560	2,43	2,71	2,99	3,27	42,0	14,0	8,4
		9,6	10,6	11,1	11,7	5,0	45,0	76,5	675	2,56	2,85	3,14	3,43	48,2	16,1	9,6
		10,4	11,5	12,1	12,7	5,5	46,5	79,1	708	2,65	2,95	3,25	3,55	48,8	16,3	9,8
90	24	260	300	350	380					260	300	350	380			
		5,1	5,3	5,7	5,9	3,0	39,0	66,3	622	1,81	2,06	2,38	2,57	50,9	17,0	10,2
	26	6,6	6,9	7,3	7,7	4,0	44,0	74,8	720	2,07	2,35	2,71	2,92	51,6	17,2	10,3
		7,3	7,7	8,3	8,8	4,0	47,0	79,9	845	2,22	2,53	2,91	3,13	56,3	18,8	11,3
	28	8,9	9,4	10,2	10,7	5,0	52,0	88,4	945	2,49	2,83	3,25	3,50	56,2	18,7	11,2
		9,9	10,6	11,6	12,3	5,0	56,0	95,2	1095	2,71	3,07	3,52	3,79	59,9	20,0	12,0
		10,8	11,6	12,7	13,4	5,5	57,0	96,9	1150	2,76	3,13	3,59	3,87	61,7	20,6	12,3
100	26	210	250	270	300					210	250	270	300			
		4,5	4,7	4,8	4,9	3,0	42,0	71,4	732	1,62	1,90	2,03	2,23	53,9	18,0	10,8
	28	5,8	6,1	6,2	6,4	4,0	47,0	79,9	845	1,84	2,15	2,30	2,53	54,8	18,3	11,0
		6,2	6,5	6,7	7,0	4,0	51,0	86,7	980	2,02	2,35	2,52	2,77	57,9	19,3	11,6
	30	7,6	8,0	8,2	8,5	5,0	56,0	95,2	1095	2,25	2,62	2,80	3,07	58,1	19,4	11,6
		8,2	8,7	9,0	9,4	5,0	57,0	96,9	1260	2,30	2,67	2,85	3,13	65,5	21,8	13,1
		8,9	9,5	9,8	10,2	5,5	58,5	99,5	1320	2,37	2,75	2,94	3,22	66,6	22,2	13,3
110	28	200	250							200	250					
		4,3	4,5			3,0	44,0	74,8	848	1,64	2,00			58,9	19,6	11,8
	30	5,5	5,8			4,0	51,0	86,7	980	1,94	2,35			57,5	19,2	11,5
		5,8	6,1			4,0	52,0	88,4	1127	1,99	2,41			64,7	21,6	12,9
	32	7,1	7,5			5,0	57,0	96,9	1260	2,21	2,67			65,0	21,7	13,0
		7,5	8,0			5,0	58,0	98,6	1432	2,25	2,72			72,4	24,1	14,5
		7,7	8,2			5,5	60,0	102,0	1330	2,35	2,83			64,6	21,5	12,9