



Illustrative purposes only; the model shown here could be different that one supplied

STANDARD EQUIPMENT

- High efficiency partial flow turbine drive directly coupled to the gearbox (minimum pressure losses in its category)
- 4 speed gearbox with oil lubrication
- Safety devices for PTO and rewinding out of the drum
- Moving transmission through toothed crown, which is placed close to the maximum stress point on the drum and not pushing against the hose reel borders
- Leadscrew driven hose layering guide
- By-pass “double action” for automatic speed control
- Glycerine filled pressure gauge
- Digital hour meters
- Huge diameter 360° turntable
- Hydraulic system for turntable rotation, trolley lift, drawbar jack and independent wheels lifting, actioned by distributor lever situated on one side of the machine
- Trolley lift and stacker legs driven by hydraulic pistons incorporated inside the structure
- Hot galvanised steel frame, pipework with double water inlet and components
- 2 wheels hot galvanised sprinkler trolley with adjustable track, height and legs
- Accident prevention protections according to CE standard
- Sprinkler with set of nozzles
- High resistant medium density PE hose with differentiated thickness
- Instructions and maintenance handbook
- CE Certificate
- Warranty certificate

Available Models

Structure	Model	Type	Ending hose	P.E. Hose Ø (mm)	Hose length (m)	Sprinkler
GHA	100 / 500	C	2	100	500	REFLEX / TWIN 140
	100 / 550	C	5	100	550	REFLEX / TWIN 140
	110 / 420	B	10	110	420	REFLEX / TWIN 160
	110 / 450	A	4	110	450	REFLEX / TWIN 160
	110 / 470	A	5	110	470	REFLEX / TWIN 160
	110 / 500	D	4	110	500	REFLEX / TWIN 160
	110 / 540	H	5	110	540	REFLEX / TWIN 160
	120 / 440	L	10	120	440	EXPLORER / TWIN 202
	125 / 300	F	3	125	300	EXPLORER / TWIN 202
	125 / 340	F	5	125	340	EXPLORER / TWIN 202
	125 / 380	L	8	125	380	EXPLORER / TWIN 202
	125 / 400	L	9	125	400	EXPLORER / TWIN 202
	140 / 280	M	3	140	280	EXPLORER / TWIN 202
	140 / 300	M	4	140	300	EXPLORER / TWIN 202

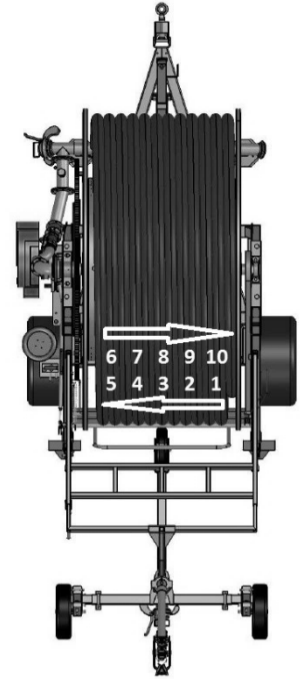

Weight and overall dimensions

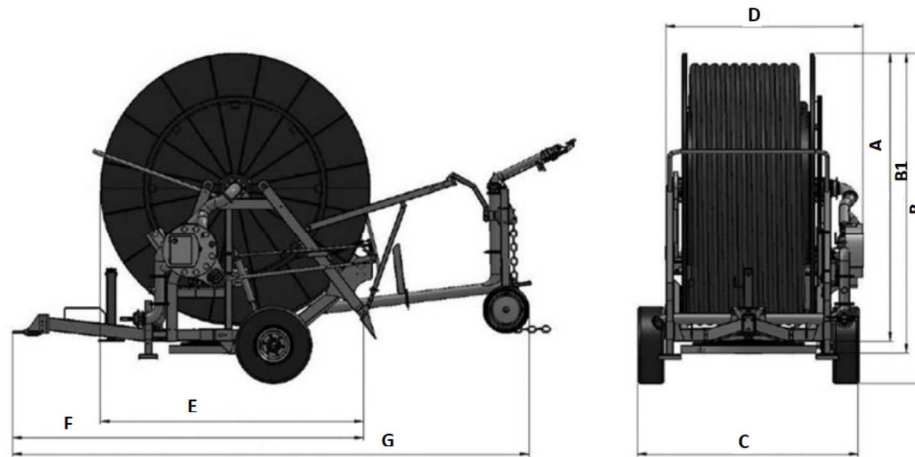

STR.	TYPE	WHEELS	A	B	B1	C	D	E	F	G	KG
GHA	A	10.0/75.15.3-6F	2870	3320	3010	2450	2220	2820	3950	5850	3350 ÷ 4200
	A	11.5/80.15.3-6F	2870	3360	3010	2460	2220	2820	3950	5850	
	A	13.0/55.16-6F	2870	3330	3010	2570	2220	2820	3950	5850	
	A	400/60.15.3-6F	2870	3360	3010	2660	2220	2820	3950	5850	
	B	10.0/75.15.3-6F	2870	3320	3010	2450	2220	2820	3950	5850	
	B	11.5/80.15.3-6F	2870	3360	3010	2460	2220	2820	3950	5850	
	B	13.0/55.16-6F	2870	3330	3010	2570	2220	2820	3950	5850	
	B	400/60.15.3-6F	2870	3360	3010	2660	2220	2820	3950	5850	
	C	10.0/75.15.3-6F	2900	3350	3040	2450	2220	2850	3950	5850	
	C	11.5/80.15.3-6F	2900	3390	3040	2460	2220	2850	3950	5850	
	C	13.0/55.16-6F	2900	3360	3040	2570	2220	2850	3950	5850	
	C	400/60.15.3-6F	2900	3390	3040	2660	2220	2850	3950	5850	
	D	10.0/75.15.3-6F	3130	3590	3270	2450	2220	3020	4050	5950	
	D	11.5/80.15.3-6F	3130	3630	3270	2460	2220	3020	4050	5950	
	D	13.0/55.16-6F	3130	3600	3270	2570	2220	3020	4050	5950	
	D	400/60.15.3-6F	3130	3630	3270	2660	2220	3020	4050	5950	
	E	10.0/75.15.3-6F	3130	3590	3270	2450	2220	3020	4050	5950	
	E	11.5/80.15.3-6F	3130	3630	3270	2460	2220	3020	4050	5950	
E	13.0/55.16-6F	3130	3600	3270	2570	2220	3020	4050	5950		
E	400/60.15.3-6F	3130	3630	3270	2660	2220	3020	4050	5950		

STR.	TYPE	WHEELS	A	B	B1	C	D	E	F	G	KG
GHA	F	10.0/75.15.3-6F	3130	3590	3270	2450	2220	3020	4050	5950	3350 ÷ 4200
	F	11.5/80.15.3-6F	3130	3630	3270	2460	2220	3020	4050	5950	
	F	13.0/55.16-6F	3130	3600	3270	2570	2220	3020	4050	5950	
	F	400/60.15.3-6F	3130	3630	3270	2660	2220	3020	4050	5950	
	H	10.0/75.15.3-6F	3180	3640	3320	2450	2220	3070	4050	5950	
	H	11.5/80.15.3-6F	3180	3680	3320	2460	2220	3070	4050	5950	
	H	13.0/55.16-6F	3180	3650	3320	2570	2220	3070	4050	5950	
	H	400/60.15.3-6F	3180	3680	3320	2660	2220	3070	4050	5950	
	L	10.0/75.15.3-6F	3180	3640	3320	2450	2220	3070	4050	5950	
	L	11.5/80.15.3-6F	3180	3680	3320	2460	2220	3070	4050	5950	
	L	13.0/55.16-6F	3180	3650	3320	2570	2220	3070	4050	5950	
	L	400/60.15.3-6F	3180	3680	3320	2660	2220	3070	4050	5950	
	M	10.0/75.15.3-6F	3180	3640	3320	2450	2220	3070	4050	5950	
	M	11.5/80.15.3-6F	3180	3680	3320	2460	2220	3070	4050	5950	
M	13.0/55.16-6F	3180	3650	3320	2570	2220	3070	4050	5950		
M	400/60.15.3-6F	3180	3680	3320	2660	2220	3070	4050	5950		

Technical Features

Ø hose (mm)	Ø nozzle (mm)	Machine pressure (atm)					Sprinkler press. (atm)	Throw (mt)	Irrigated width (mt)	Flow (l/min)	Irrigated area (ha)					Rainfall (mm)		
		500	550								500	550						
100	26	6,2	6,6				3,0	42,0	71,4	732	3,59	3,93				58,1	19,4	11,6
		8,0	8,6				4,0	47,0	79,9	845	4,05	4,43				59,5	19,8	11,9
	28	9,1	9,8				4,0	51,0	86,7	980	4,41	4,83				63,3	21,1	12,7
		11,2	12,0				5,0	56,0	95,2	1095	4,88	5,33				64,0	21,3	12,8
	30	12,8	13,9				5,0	57,0	96,9	1260	4,97	5,43				72,2	24,1	14,4
		14,0	15,1				5,5	58,5	99,5	1320	5,11	5,58				73,6	24,5	14,7
110	28	420	450	470	500	540					420	450	470	500	540			
		5,4	5,5	5,7	5,9	6,2	3,0	44,0	74,8	848	3,20	3,42	3,56	3,77	4,06	63,4	21,1	12,7
	7,0	7,1	7,4	7,6	8,0	4,0	51,0	86,7	980	3,75	4,00	4,17	4,41	4,74	62,5	20,8	12,5	
	30	7,7	7,9	8,2	8,5	9,1	4,0	52,0	88,4	1127	3,83	4,09	4,25	4,51	4,84	70,4	23,5	14,1
		9,4	9,7	10,1	10,4	11,1	5,0	57,0	96,9	1260	4,23	4,51	4,70	4,97	5,34	71,2	23,7	14,2
	32	10,4	10,7	11,3	11,6	12,5	5,0	58,0	98,6	1432	4,32	4,60	4,78	5,07	5,44	79,4	26,5	15,9
10,3		10,6	11,1	11,4	12,1	5,5	60,0	102,0	1330	4,48	4,77	4,96	5,25	5,64	71,1	23,7	14,2	
120	30	440								440								
		6,7					4,0	52,0	88,4	1127	4,00					48,1	16,0	9,6
	8,2					5,0	56,0	95,2	1260	4,34					49,7	16,6	9,9	
	32	8,9					5,0	58,0	98,6	1432	4,50					54,4	18,1	10,9
		10,5					6,0	62,0	105,4	1570	4,84					55,4	18,5	11,1
	34	9,7					5,0	59,0	100,3	1618	4,59					60,3	20,1	12,1
11,4						6,0	64,0	108,8	1773	5,01					60,5	20,2	12,1	
125	32	300	340	380	400					300	340	380	400					
		5,9	6,1	6,4	6,5		4,0	54,0	91,8	1282	2,95	3,30	3,64	3,82		74,4	24,8	14,9
	7,2	7,4	7,8	7,9		5,0	58,0	98,6	1432	3,19	3,57	3,94	4,13		76,7	25,6	15,3	
	36	8,1	8,5	9,0	9,2		5,0	61,0	103,7	1813	3,38	3,77	4,17	4,36		91,8	30,6	18,4
		9,6	10,0	10,6	10,8		6,0	66,0	112,2	1988	3,69	4,12	4,54	4,76		92,1	30,7	18,4
	38	8,7	9,1	9,7	10,0		5,0	63,0	107,1	2022	3,50	3,91	4,32	4,52		98,7	32,9	19,7
10,3		10,8	11,5	11,8		6,0	68,0	115,6	2215	3,82	4,26	4,70	4,92		99,2	33,1	19,8	
140	34	280	300							280	300							
		6,6	6,7				5,0	59,0	100,3	1618	3,06	3,25				82,6	27,5	16,5
	7,8	7,9				6,0	64,0	108,8	1773	3,36	3,57				82,5	27,5	16,5	
	36	6,8	6,9				5,0	61,0	103,7	1813	3,18	3,38				89,1	29,7	17,8
		8,1	8,2				6,0	66,0	112,2	1988	3,48	3,69				89,3	29,8	17,9
	38	7,1	7,3				5,0	63,0	107,1	2022	3,30	3,50				95,7	31,9	19,1
8,4		8,6				6,0	68,0	115,6	2215	3,60	3,82				96,1	32,0	19,2	